

10-1

Unit 10. Oxidation-Reduction Chemistry

Oxidation and Reduction are opposites: Can't have one without the other.

10-2

Redox in Your Life

- Rusting of your car
- Heating your home in winter
- Batteries

10-3

Oxidation - the Gain of Oxygen
Reduction - the Loss of Oxygen

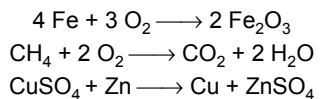

10-4

Oxidation - the Loss of Hydrogen
Reduction - the Gain of Hydrogen

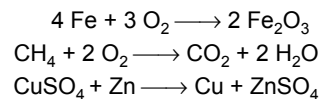

10-5

How do We Reconcile the Discrepancies?

Oxidation State- the charge that develops on an atom in order to satisfy the octet rule.

10-6

Oxidation is the Loss of Electrons
Reduction is the Gain of Electrons

Mnemonic device: OIL RIG

10-7

Rules for Determining Oxidation State

1. *Elemental atoms* have oxidation state of zero.
Elemental atoms- atoms that are uncombined with atoms of other elements.
2. Main group elements have the expected oxidation state.
3. Calculate oxidation state of transition elements and group IVA elements.
4. The sum of charges on a molecule must equal 0; must equal the charge of polyatomic ions.

10-8

Sample Test Questions

1. Determine the oxidation state of carbon in the following molecules: CH₄, CO, CO₂

10-9

Sample Test Questions

1. Determine the oxidation state of carbon in the following molecules: CH₄, CO, CO₂
2. Determine the oxidation state of the underlined atom in the following molecules:
FeCl₂, FeCl₃, Fe(NO₃)₂, Fe₃(PO₄)₂

10-10

Definitions

Oxidizing agent- reactant molecule which oxidizes an atom of another element in a reaction. Since redox reactions occur only in pairs, the oxidizing agent contains the reduced element.

Reducing agent- reactant molecule which reduces an atom of another element in a reaction. The reducing agent contains the oxidized element.

10-11

Sample Test Questions

1. In the reaction, $\text{Fe}_2\text{O}_3 + 3 \text{C} \longrightarrow 2 \text{Fe} + 3 \text{CO}$, identify:
 - a) the element that is oxidized
 - b) the element that is reduced
 - c) what the oxidizing agent is
 - d) what the reducing agent is
2. In the reaction, $\text{C}_2\text{H}_4 + \text{H}_2 \longrightarrow \text{C}_2\text{H}_6$, identify:
 - a) the element that is oxidized
 - b) the element that is reduced
 - c) what the oxidizing agent is
 - d) what the reducing agent is

10-12

Problem Assignment 5 - Due 11/22/99

Three multipart problems on the web page

10-13

Activity Series

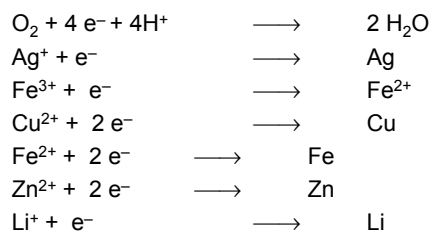

Oxidize down/right

Reduce up/left

10-14

Sample Test Questions

- Will Cu^{2+} oxidize F_2 ?
- Predict whether the following reaction would be expected to occur: $2 \text{Na} + \text{Fe}^{2+} \longrightarrow 2 \text{Na}^+ + \text{Fe}$

10-15

Application of the Activity Series

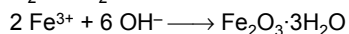
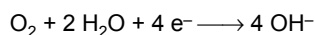
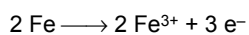

Galvanizing- coating of iron with Zinc

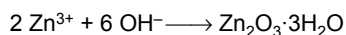
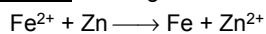

10-16

Batteries

There are a lot of different kinds of batteries
Be sure to read §8.4.

Primary battery- (nonrechargeable) the redox reaction cannot be reversed.

Rechargeable battery- chemical and electrical energy can be converted back and forth.

10-17

Electrochemical Cells and Batteries

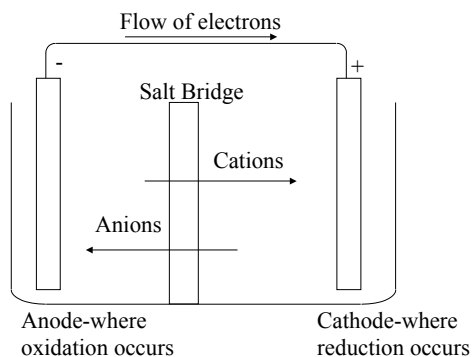

10-18

One Example: The NiCad Battery

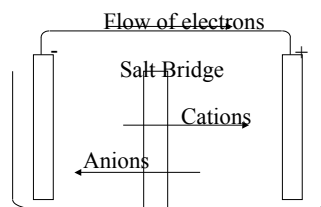

Ox rxn:



Red rxn:

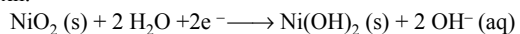

10-19

Sample Test Questions

- The following reaction is one of two that occurs in a battery. At which electrode does this reaction take place? $\text{MnO}_2 + \text{H}_2\text{O} \longrightarrow \text{MnO}(\text{OH}) + \text{OH}^-$

10-20

Electrolysis

Used often to purify chemicals: H_2 , O_2 , Cu , Al , Fe

10-21

Electrolysis of Water

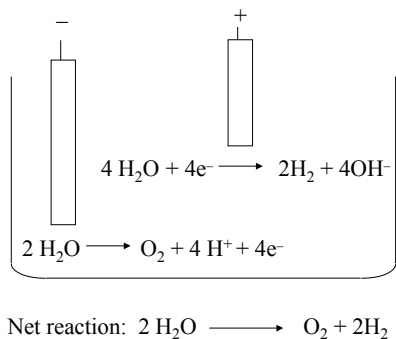

10-22

Electrolysis of Metal Ores (Al, Fe)

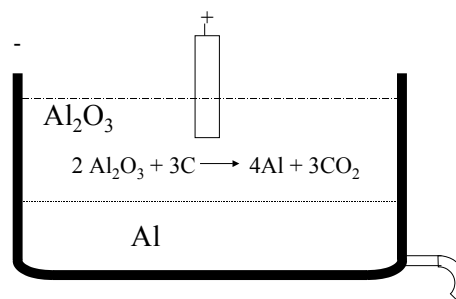

10-23

Electroplating

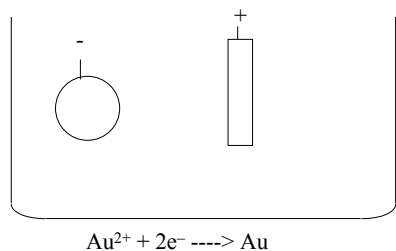

10-24

Exam III Back

- Check my math.
- Make sure you can answer questions.
- See if you think it's a fair question.
Any challenges to assigned score must be made within one week.
 High was 82, average 57.5: 18 point curve